

IMSAB COMPONENT GUIDE for industry and shipping

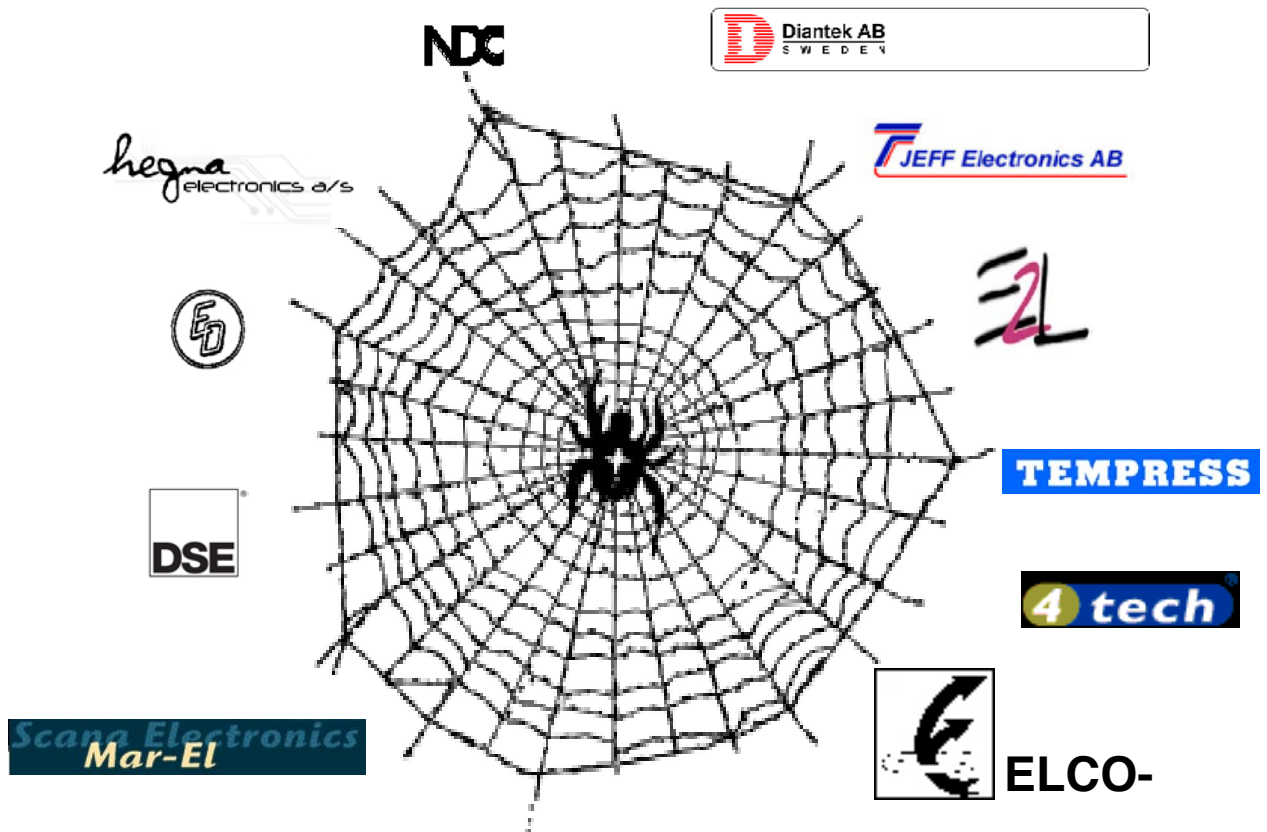

Operation alarm system LB 10



ALARM SYSTEM LB 10

FOR SPECIALIZED DUTIES IN INDUSTRY AND ON BOARD

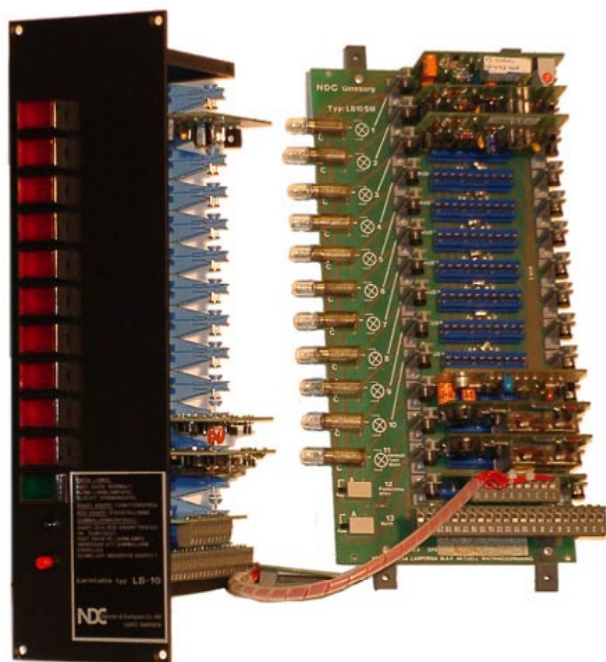

- 10 channel display unit for plug-in channel cards, for both No/Nc contacts.
- Up to 9 slave units can be used, to give a total of 100 alarm channels.
- 2 or 4 alarm groups can be selected and grouped (A-B-C-D alarm)
- Time delay on each channel
- Can be supplied for uses with separate indicator lamps.
- Running light with faulty lamp indication
- NDC:s group alarm test
- Voltage failure indication
- Prepared for datatransfer
- Certificated in CE-standards EN 50 082-2

ADVANTAGES AND OPERATION

The LB 10 unit comprises a range of plug-in channel cards, which determine the function of the unit. The most frequent types are shown in the ordering instructions. The cards can be programmed for normally open or closed sensor contacts. A fault signal activates the timer on the card. After the individually pre-set time has elapsed the indicator lamp starts to flash, while at the same time the output relay for the group involved, is activated. The signal is acknowledged by pressing the common red accept button, which resets the output contacts and changes the lamp to steady light. Finally, when the sensor contacts return to their normal state, the indicator lamp goes out. LB 10 can be supplied in a version without indicator lamps, for use in a mimic diagram or similar types of display. **Functions test** can be done with a push at the BLACK button, which simulate fault at the panel. **Lamp test** can be done with a push at the button BLACK + RED button at same time.

SECURITY

LB-10 is designed for severe mechanical and electrical environmental conditions. It is provided with protection against polarity reversal and accidental connection of voltage. The unit is designed to indicate voltage failures; each group relay is normally activated. In the alarm state the relay is deactivated and a signal can be given with, for example a horn. The same happens when the supply voltage is interruption. Normal function testing is carried out by pressing the black button, which simulates a fault on each alarm channel. In addition, the unique group alarm test gives a more sophisticated safety - assurance test. It checks that each individual alarm point contributes to its group output. LB 10 is fitted with a running light indicator, to confirm that the power is connected. Lamps are checked manually by pressing the black function test button and the red accept button, at the very simultaneously. The cards fit into strong guide rails and can be locked into position. The unit is in accordance with CE-standards: EN 50 082-2; IEC 801-2:1991; ENV 50 140; ENV 50 141; IEC 801-4

INSTALLATION

LB 10 is designed for panel mounting. The unit is available in both master and slave versions, and the system can, therefore, be built up in stages, or from the start, comprise, one master and up to 9 slave units. The test and accept facilities are provided only on the master unit which carries out these function on behalf of the slave units. The unit is connected through plug-in terminal cards. One of these is for the external leads and the other for internal connections between the master and slave units. This makes connection very simple, whilst allowing for easy separation of the complete unit.

SPECIFICATIONS

Supply voltage: 24 or 48V DC \pm 20% smoothed or unsmoothed. Filtering not required.
 Supply current: Normal condition 0,2A per unit.
 Alarm condition (max) 0,7A per unit.
 Time delay: 0,5-20 sec. adjustable for each alarm card.
 No of alarm groups:
 2 or 4 per system (A-B-C-D alarm).
 Output contacts: One change - over contact per alarm group.
 Contacts rating 100V, 100VA, resistive load.
 Front: Dull black aluminium.
 Legends: Space for legends 50x15 mm, or engraved on lamp screens.
 Indicator: Red lamps = faulty indication (Ba9s 24V 50 mA or 48V 40mA)
 Main dimension: 350x96x155 mm, panel mounting.



330x150x75 mm, terminal mounting.
 Panel recess: 330x76 mm (for service handling, we recommend 20 mm between each panels)
 Max permissible external cable resistance: 1000 ohm.

ORDERING INSTRUCTIONS

13010 LB 10 M: Master for panel mounting
 13011 LB 10 S: Slave for panel mounting
 13020 LB 10 MP: Master for terminal mounting
 13021 LB 10 SP: Slave for terminal mounting

Alarm cards:
 LBC: Alarm card with memory and flashing light
 LBCR: Alarm card with memory, flashing light and signal contact

Extra output cards:
 LBRR: Output card for (C-D alarm)
 LBURUR: Output card for sub-central outputs

Special cards:
 LBB: Alarm card without memory and without flashing light
 LBCRD: Alarm card with LED, memory, flashing light and signal contact
 LBCU: Alarm card with sub-central function
 LBCRU: Alarm card with sub-central function and signal contact
 LBCRDU: Alarm card with signal contact, sub-central function and LED (for use with separate lamp connector).

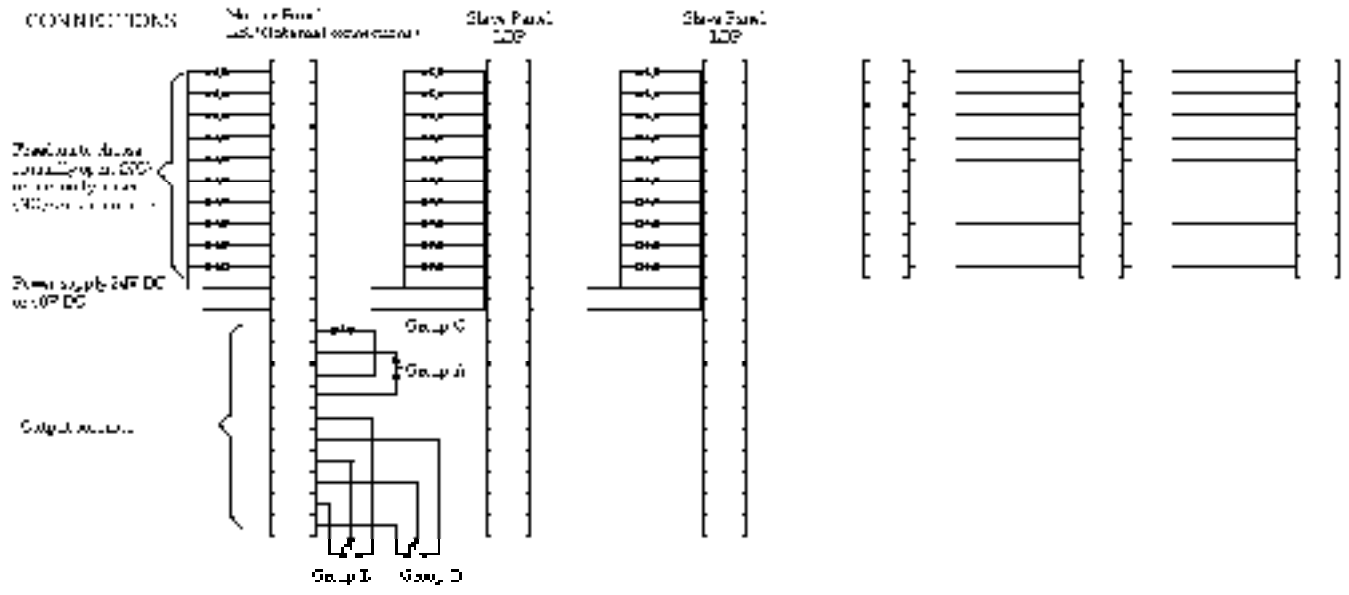
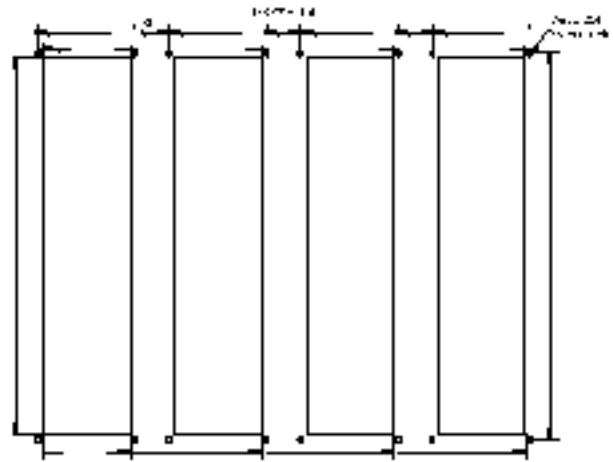
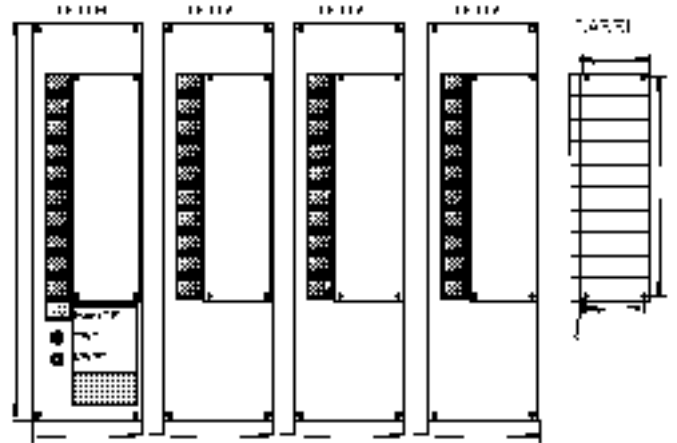

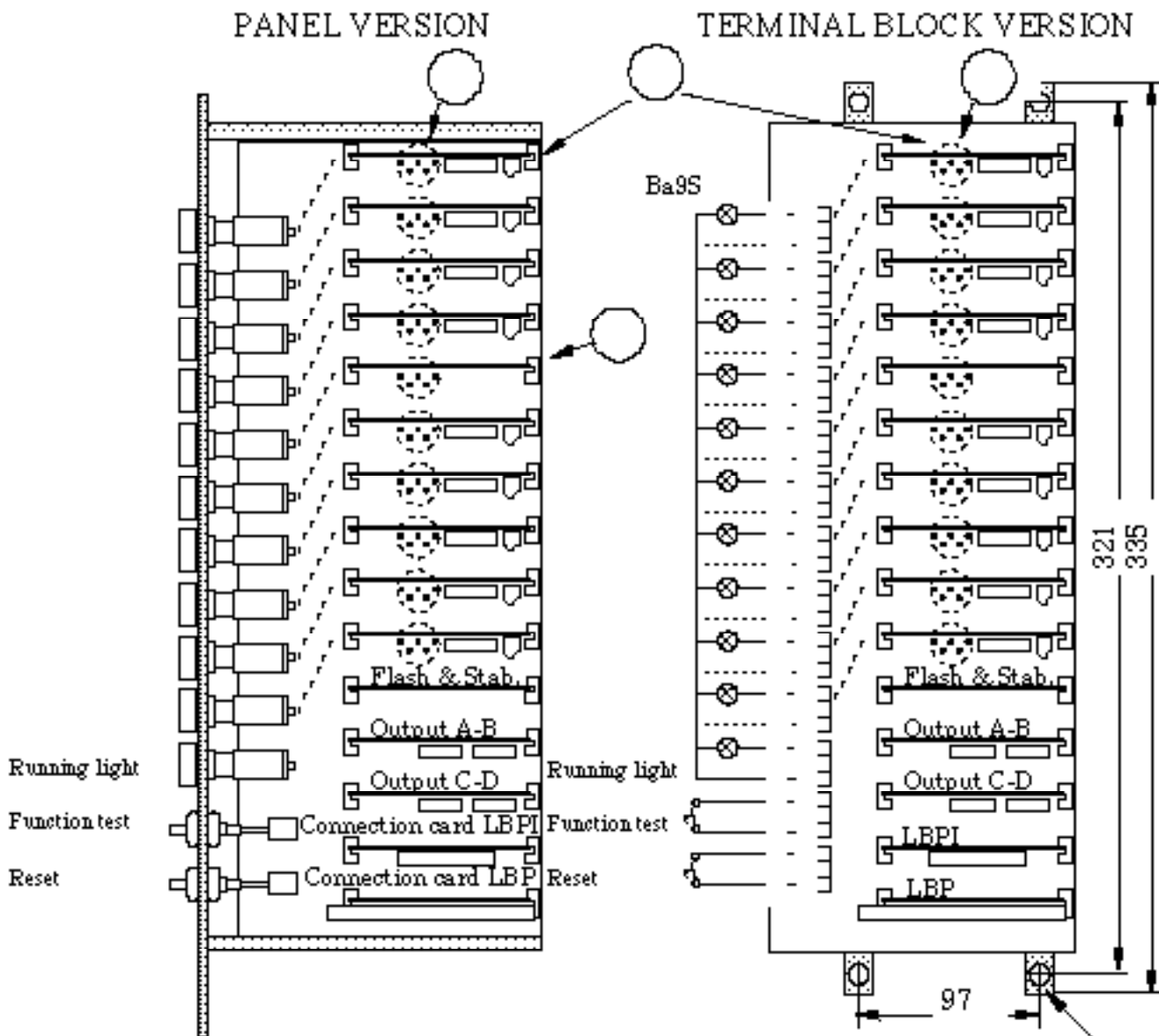

Not 1
Alarm grouping pin to be placed as below

- Group A
- Group B
- Group C
- Group D

Not 2
Alarm channel card LBCR

Note 4
Alarm channel card LBC

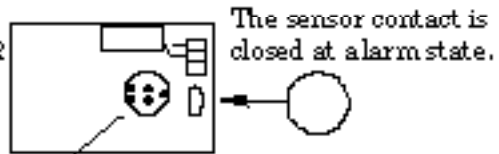

- Sensor contact normally closed (NC)
- Sensor contact normally open (NO)



Note 3
Time delay

